

A-A
SCALE: 1 : 5

Flat Pattern view
SCALE: 1:20

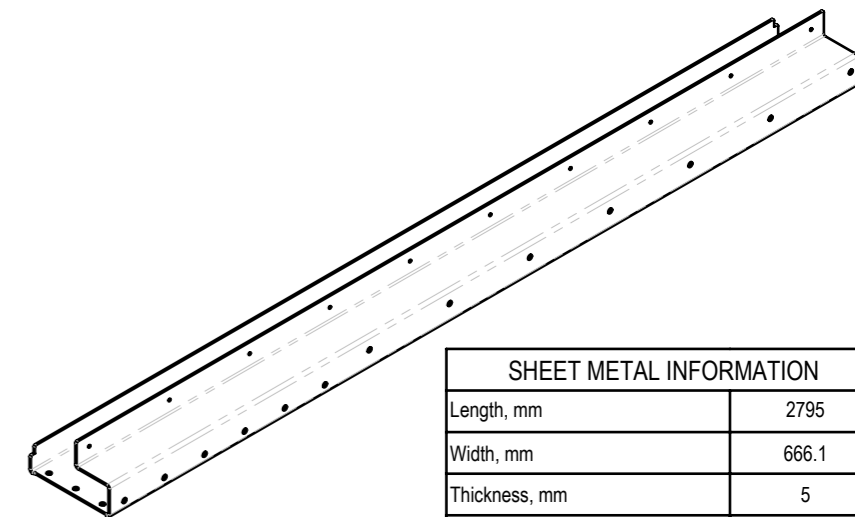
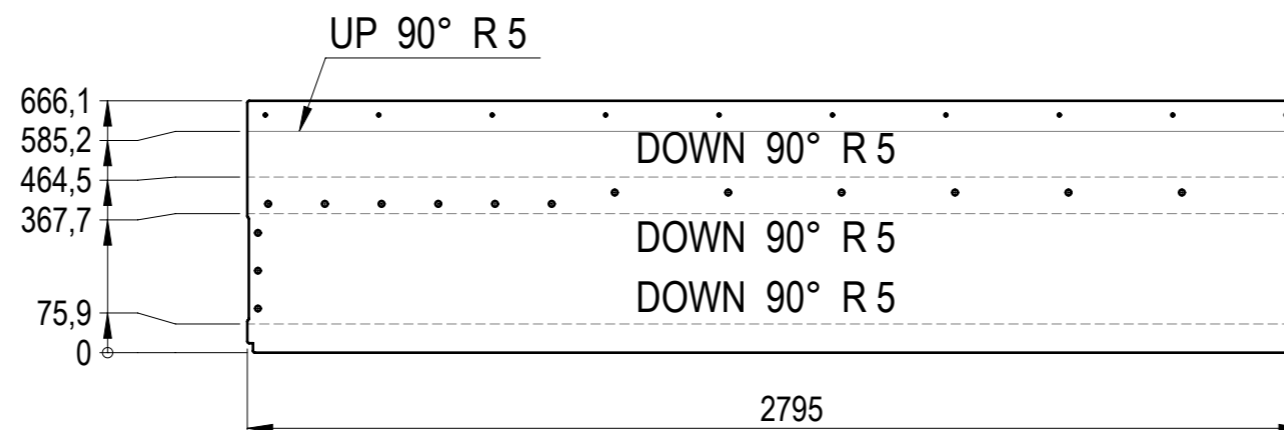
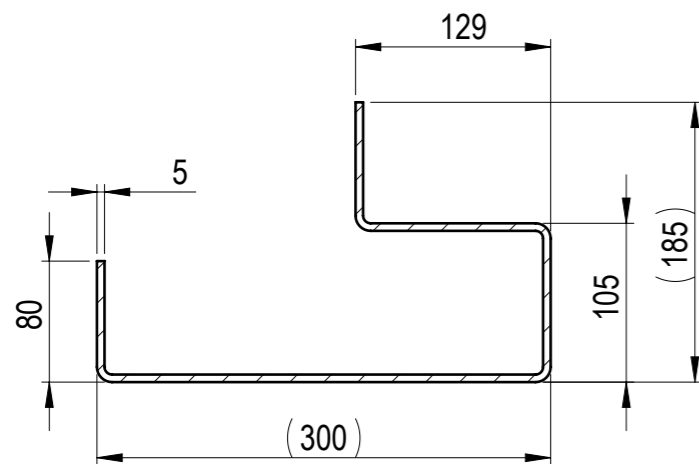

SHEET METAL INFORMATION	
Length, mm	2795
Width, mm	666.1
Thickness, mm	5
Inside Bend Radius, mm	5
K-Factor	0.5
No. of Bends	4

Other dimensions from .DXF file.

WEMPS ENGINEERING SERVICES	MATERIAL	WEIGHT	DEBURR AND BREAK SHARP EDGES DO NOT SCALE DRAWING		REVISION	DATE	
	S355J2	72.348 Kg				25.03.2025	
	SURFACE PROTECTION	MACHINING	THERMAL CUTTING	WELDING	SCALE	FORMAT	
	HDG EN ISO 1461	ISO 2768 mK	ISO 9013 441	ISO 13920 BF	1:10	A3	
	NAME	SIGNATURE	PART NO.			105-05000-02	
Designed by	D. Dislers		DESCRIPTION				
Drawn by	E. Kriviss		Return air channel bracket				
Technical ref.						SHEET 1/1	